

## Chef's Tables

CTHR-100: Half Round Chef's Table   CTCF-100: Chef's Sandwich Table   CTFP-100: Chef's Table with Cooktops

Carts of Colorado designed their line of Chef's Tables to be elegant and functional. Featuring Infrared or Induction Cooktops, the Chef's Tables offer state-of-the-art cooking options to meet any need. Maintain your upscale reputation by serving your guests from these handsome, customizable units, available in several wood grains with an easy-to-clean choice of countertops that include granite, solid surface or laminate.

The Club Level Carts from Carts of Colorado were built to be portable and functional, with sophistication in mind. Elegantly made of wood with a choice of countertops, these carts will attract customers — and maximize profits. Carts of Colorado offers custom designs, so call us today to see how we can meet your specific needs.



*Chef's Sandwich Table  
CTCF-100*



*Chef's Table with Cooktops  
CTFP-100*



*Half Round Chef's Table  
CTHR-100*

# Chef's Tables

CTHR-100: Half Round Chef's Table    CTCF-100: Chef's Sandwich Table    CTFP-100: Chef's Table with Cooktops

## Half Round Chef's Table – CTHR-100

Base electrical: 120/20 amp

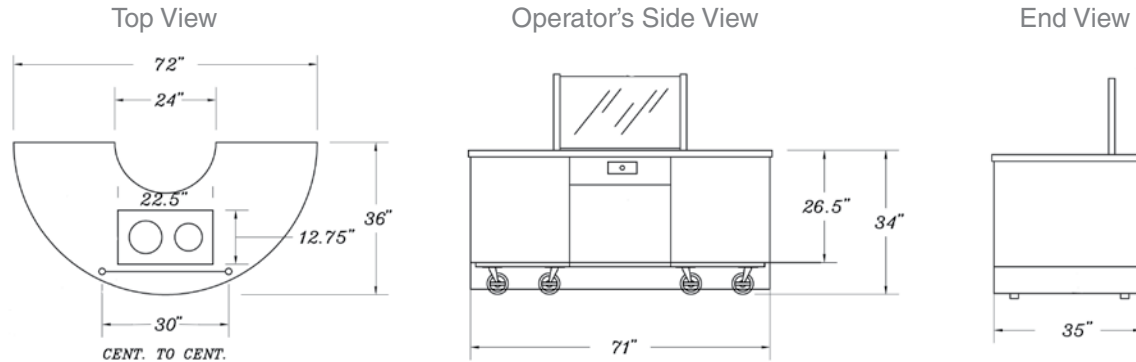

## Chef's Sandwich Table – CTCF-100

Base electrical: 120/30 amp

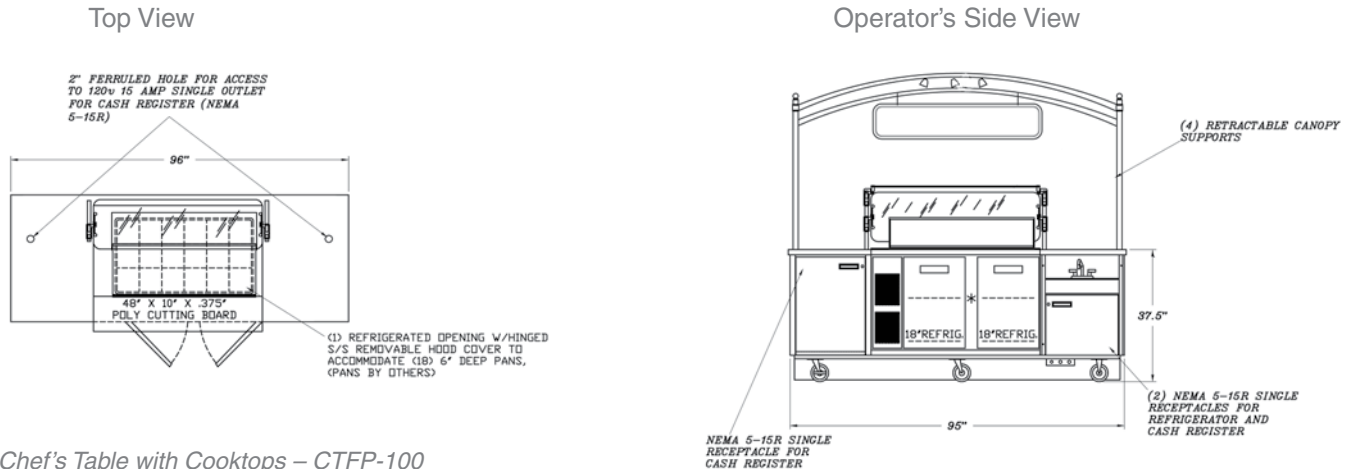

## Chef's Table with Cooktops – CTFP-100

Base electrical: 120/208/60 amp

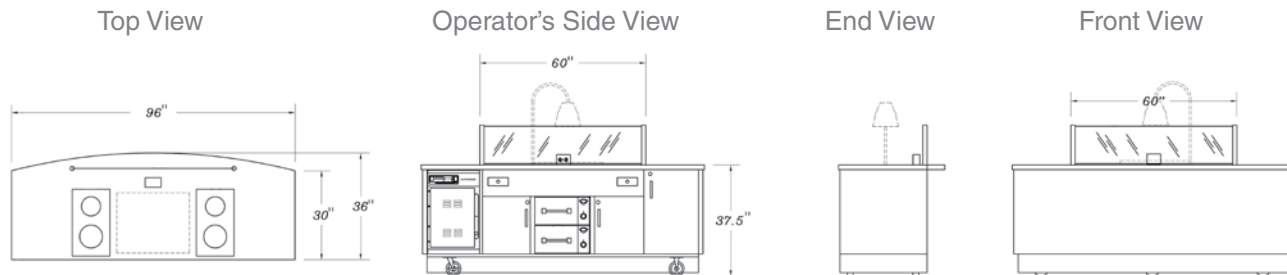

The dimensions given are reference dimensions only. Critical dimensions should be brought to the attention of the salesperson. Due to a continuous program of product improvement, Carts of Colorado reserves the right to make product changes without notice.

Installation of electrical at site not included. Buyouts provided by others do not include electrical outlets unless specified on drawing. Electrical of over 120 volts/20 amps does not include cord or cap.

This document contains information that is confidential and proprietary to Carts of Colorado and shall not be reproduced or transferred to other documents or disclosed to others or used for any purpose other than that for which it was obtained without the expressed written consent of Carts of Colorado.

It is recommended that local building, health and zoning codes be researched prior to ordering. Due to a continuous program of product improvement, Carts of Colorado reserves the right to make changes in design and in specifications without notice.

5420 S. Quebec St.  
Suite 204  
Greenwood Village, CO 80111  
(303) 329-0101  
(800) 227-8634  
Fax: (303) 329-6577  
[www.cartsofcolorado.com](http://www.cartsofcolorado.com)  
[sales@cartsofcolorado.com](mailto:sales@cartsofcolorado.com)